

USE AND MAINTENANCE MANUAL

 **FIMAP**[®]

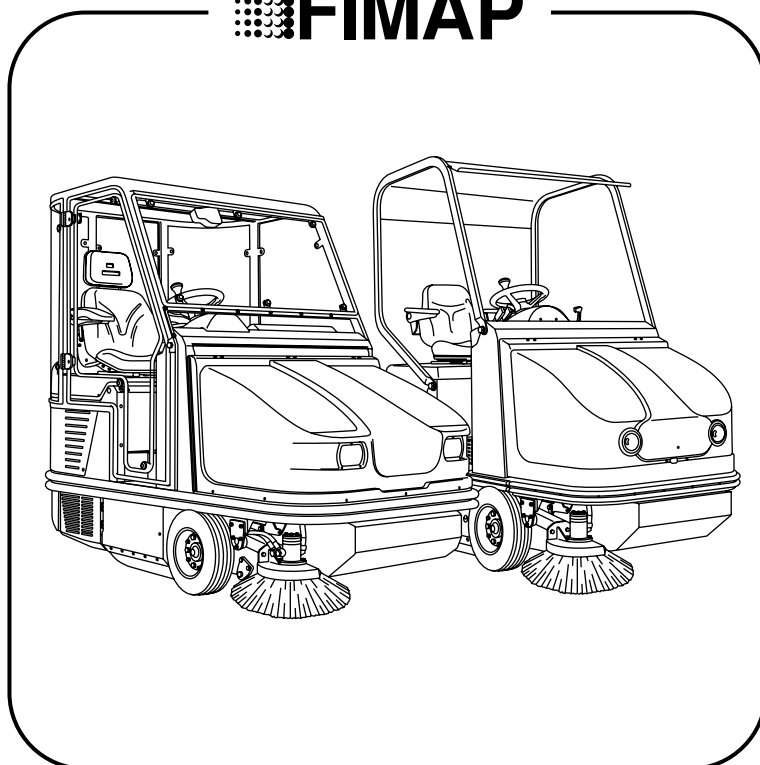

FS80/90/110 B-D
FS100/120 B-D-Bifuel

ED. 11 - 2020

Original instructions
Doc. 10021399
Ver. AD





The descriptions contained in this document are not binding.
The company therefore reserves the right to make any modifications at any time to elements, details, or accessory supply, as considered necessary for reasons of improvement or manufacturing/commercial requirements.
The reproduction, even partial, of the text and drawings contained in this document is prohibited by law.

The company reserves the right to make any technical and/or supply modifications. The images are for reference purposes only, and are not binding in terms of design and supply.

SYMBOLS USED IN THE MANUAL



Open book symbol with an "i":

Indicates that this document is an instruction manual.



Open book symbol:

Tells the operator to read the user manual before using the device.



Warning symbol:

Carefully read the sections marked with this symbol, for the safety of the operator and the machine.



Handling symbol:

You are advised to only lift and move the batteries with lifting and transportation means suitable for the specific weight and size.



Corrosive liquids symbol:

users are advised to always wear protective gloves, to avoid the risk of serious injury to hands.



Flammable symbol:

Indicates the danger of fire.
Keep naked flames at a safe distance.



CONTENTS

GENERAL SAFETY RULES	5
ON CONSIGNMENT OF THE MACHINE	6
INTRODUCTORY COMMENT	6
SERIAL NUMBER PLATE	5
BATTERY VERSION TOOLS	7
DIESEL AND BIFUEL VERSION TOOLS	8
BATTERY VERSION TOOLS (ROAD)	9
DIESEL VERSION TOOLS (ROAD)	10
COMMANDS AND SYMBOLS USED ON THE MACHINE	
VERSIONS 80-90-110.....	11
VERSIONS 100-120.....	12
VERSIONS 100-120 (ROAD)	13
HOW TO UNPACK THE MACHINE	
1. HANDLING THE PACKED MACHINE.....	14
2. HOW TO UNPACK THE MACHINE	14
3. GETTING THE MACHINE DOWN FROM THE PALLET.....	14
PREPARATION OF MACHINE	
1. HANDLING THE UNPACKED MACHINE	15
2. INSERTING/CONNECTING THE BATTERIES (BATTERY VERSIONS ONLY)	16
3. BATTERY CHARGER CONNECTION	16
4. SIDE BRUSH ADJUSTMENT.....	17
INITIAL START-UP AND USE OF THE MACHINE	
1. MACHINE START-UP.....	18
2. FILTER SHAKER ACTIVATION AND DEBRIS HOPPER EMPTYING	20
3. FRONT VACUUM HOSE KIT	20
RECOMMENDED MAINTENANCE	
1. FILTER CLEANING	22
2. SIDE BRUSH ADJUSTMENT.....	22
3. CENTRAL BRUSH PRESSURE ADJUSTMENT.....	23
4. CENTRAL BRUSH REPLACEMENT	23
5. LID FLAP RUBBER REPLACEMENT	23
6. REAR FLAP RUBBER REPLACEMENT.....	23
7. HYDRAULIC TRANSMISSION MAINTENANCE	24
8. HYDRAULIC OIL FILTER REPLACEMENT	24
9. ENGINE OIL LEVEL CHECK (D-BIFUEL).....	25
10. ENGINE AIR FILTER CLEANING	25
CHOOSING AND USING THE BRUSHES	
1. POLYPROPYLENE (PPL) BRUSH	26
2. BRISTLE THICKNESS	26
CENTRAL BRUSH TABLE	26
SIDE BRUSH TABLE	26
BATTERY CONTAINER DIMENSION	
BATTERY CONTAINER DIMENSION TABLE	26
RECOMMENDED PERIODIC MAINTENANCE OPERATIONS	
MAINTENANCE TABLE	27
REPAIR OF POSSIBLE FAILURES	
TECHNICAL PROBLEMS TABLE	28
TECHNICAL DATA	
TECHNICAL DESCRIPTION TABLE FOR MODELS 80-90-110-100-120	29
EC DECLARATION OF CONFORMITY FOR MODELS 80-90-110	30



GENERAL SAFETY REGULATIONS

Before using the machine, please read the following document carefully and follow the instructions contained herein, along with the instructions in the document supplied with the machine itself, "GENERAL SAFETY REGULATIONS" (document code 10083659).



ON CONSIGNMENT OF THE MACHINE

When the machine is delivered to the customer, an immediate check must be performed to ensure all the material mentioned in the shipping documents has been received, and also to check the machine has not been damaged during transportation. If this is the case, the carrier must ascertain the extent of the damage at once, informing our customer service office. It is only by prompt action of this type that the missing material can be obtained, and any compensation for damage successfully claimed.

INTRODUCTORY COMMENT

Even the best machines will only work well if used correctly and kept in good working order. We therefore suggest you read this instruction booklet carefully and read it again whenever difficulties arise while using the machine. If you need it, remember that our technical assistance centre, organised in collaboration with our dealers, is always at your disposal for any possible recommendation or direct intervention

CAUTION

The manual of the endothermic engine is integral part of this manual. This manual is supplied as annex.

Other manuals are also available at the assistance network:

- the spare parts manual,
- the Adjustments and Testing document,
- the electrical diagram,
- the hydraulic diagram.

When asking for spare parts, always quote the product code (MAT. COD.) and serial number (No ...) of the machine indicated in the serial number plate attached to the frame.

For the engine, refer to the plate applied on it by the manufacturer.

SERIAL NUMBER PLATE

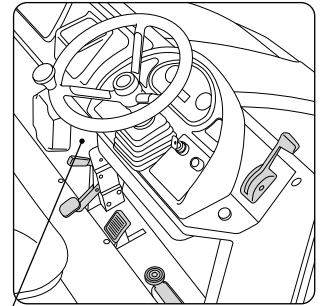

CE			
HP			
10% 		Kg	IP
Mod / Type		Cod Mat	
		N°	<input type="text"/>



BATTERY VERSION TOOLS

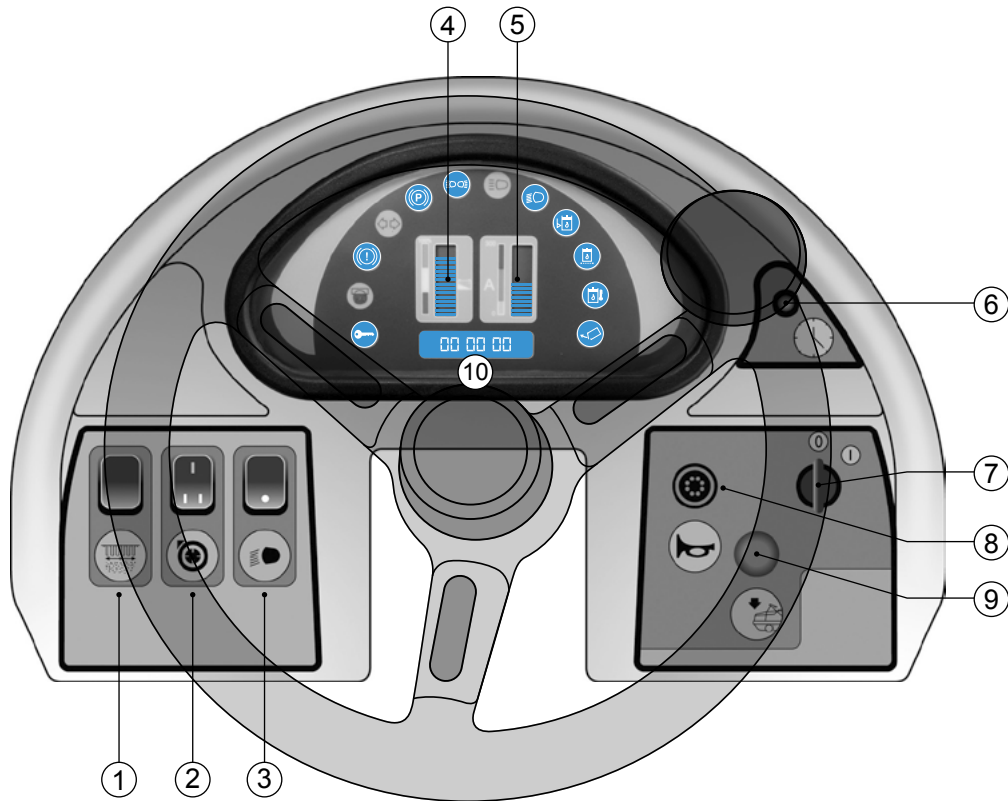

INSTRUMENT PANEL BUTTONS

- | | |
|---|---|
| 1 Filter shaker switch | 6 Partial hours display button |
| 2 Suction turbine switch (100-120 B only) | 7 Start-up key |
| 3 Headlight switch | 8 Horn |
| 4 Battery level indicator | 9 Safety button for lowering the hopper |
| 5 Current absorption indicator | 10 Hour meter. |

The number of active bars on the display (4) indicates the battery charge level; when the battery is discharged (the display indicates only one bar), a sound alarm is activated.

INSTRUMENT PANEL WARNING LIGHT

- | | |
|--|---|
| Green indicator light - key inserted
Key inserted | Red indicator light - low hydraulic oil level
Top up the level in the hydraulic circuit |
| Red indicator light - brake oil level
Insufficient brake oil level | Red indicator light - hydraulic oil filter clogged up
Check and clean the filter |
| Red indicator light - handbrake
Parking brake engaged | Red indicator light - hydraulic oil level temperature
Fault in the hydraulic circuit or radiator |
| Green indicator light - side lights
Optional for the street version | Green indicator light - hopper hatch open
Indicates the opening of the hopper hatch |
| Low-beam light green warning light
Lights on | |



DIESEL AND BIFUEL VERSION TOOLS

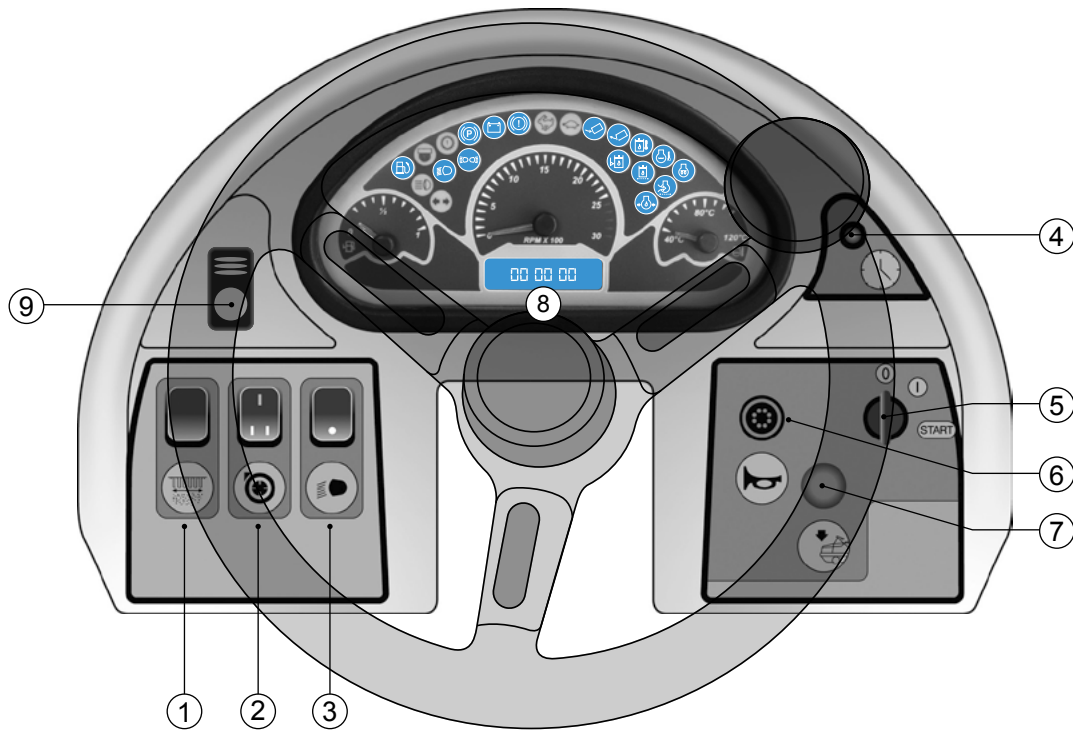

INSTRUMENT PANEL BUTTONS

- | | |
|--|--|
| 1 Filter shaker switch | 6 Buzzer |
| 2 Suction turbine switch (100-120 D-Bifuel only) | 7 Safety button for lowering the hopper |
| 3 Headlight switch | 8 Hour meter |
| 4 Partial hours display button | 9 LPG/petrol power supply switch (100-120 Bifuel only) |
| 5 Start-up key | |

INSTRUMENT PANEL WARNING LIGHT

- | | |
|--|---|
| Yellow indicator light - fuel reserve
Indicates the light oil reserve | Red indicator light - low hydraulic oil level
Top up the level in the hydraulic circuit |
| Low-beam light green warning light
Lights on | Red indicator light - hydraulic oil temperature
Fault in the hydraulic circuit or radiator |
| Green indicator light - side lights
Optional for the street version | Red indicator light - hydraulic oil filter clogged
Check and clean the filter |
| Red indicator light - handbrake
Parking brake engaged | Red indicator light - excessive motor water temperature
Stop the work operation and check the causes |
| Red indicator light - alternator not recharging the battery
Fault to be checked | Yellow indicator light - glowplugs
Activation of motor heating glowplugs |
| Red indicator light - brake oil level
Insufficient brake oil level | Red indicator light - motor air filter clogged
Disassemble and clean the filter |
| Red indicator light - hopper hatch closed
Indicates the closure of the hopper hatch | Red indicator light - low motor oil pressure alarm
Stop the work operation and check the causes |
| Green indicator light - hopper hatch open
Indicates the opening of the hopper hatch | |



BATTERY VERSION TOOLS (ROAD)

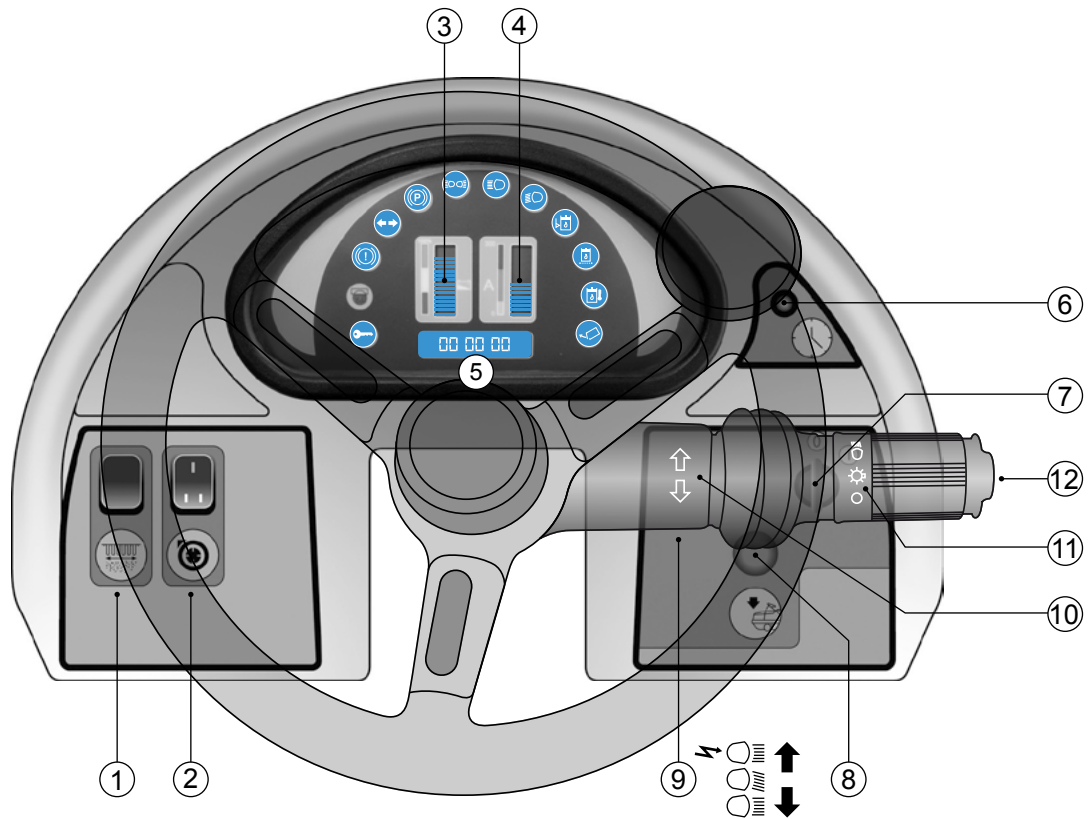

INSTRUMENT PANEL BUTTONS

- | | |
|---|--|
| 1 Filter shaker switch | 7 Start-up key |
| 2 Suction turbine switch (100-120 B only) | 8 Safety button for lowering the hopper |
| 3 Battery level indicator | 9 Light switch (raise and lower the lever) |
| 4 Current absorption indicator | 10 Direction indicators (push the lever forwards/ backwards) |
| 5 Hour meter | 11 Light controller (turn the selector) |
| 6 Partial hours display button | 12 Horn |

The number of active bars on the display (4) indicates the battery charge level; when the battery is discharged (the display indicates only one bar), a sound alarm is activated.

INSTRUMENT PANEL WARNING LIGHT

- | | |
|--|---|
| Green indicator light - key inserted
Key inserted | Green indicator light - direction indicators
Direction indicators working |
| Red indicator light - brake oil level
Insufficient brake oil level | Red indicator light - low hydraulic oil level
Top up the level in the hydraulic circuit |
| Red indicator light - handbrake
Parking brake engaged | Red indicator light - hydraulic oil filter clogged up
Check and clean the filter |
| Green indicator light - side lights
Optional for the street version | Red indicator light - hydraulic oil level temperature
Fault in the hydraulic circuit or radiator |
| Low-beam light green warning light
Lights on | Green indicator light - hopper hatch open
Indicates the opening of the hopper hatch |
| Blue indicator light - high beam headlights
Lights on | |



DIESEL VERSION TOOLS (ROAD)

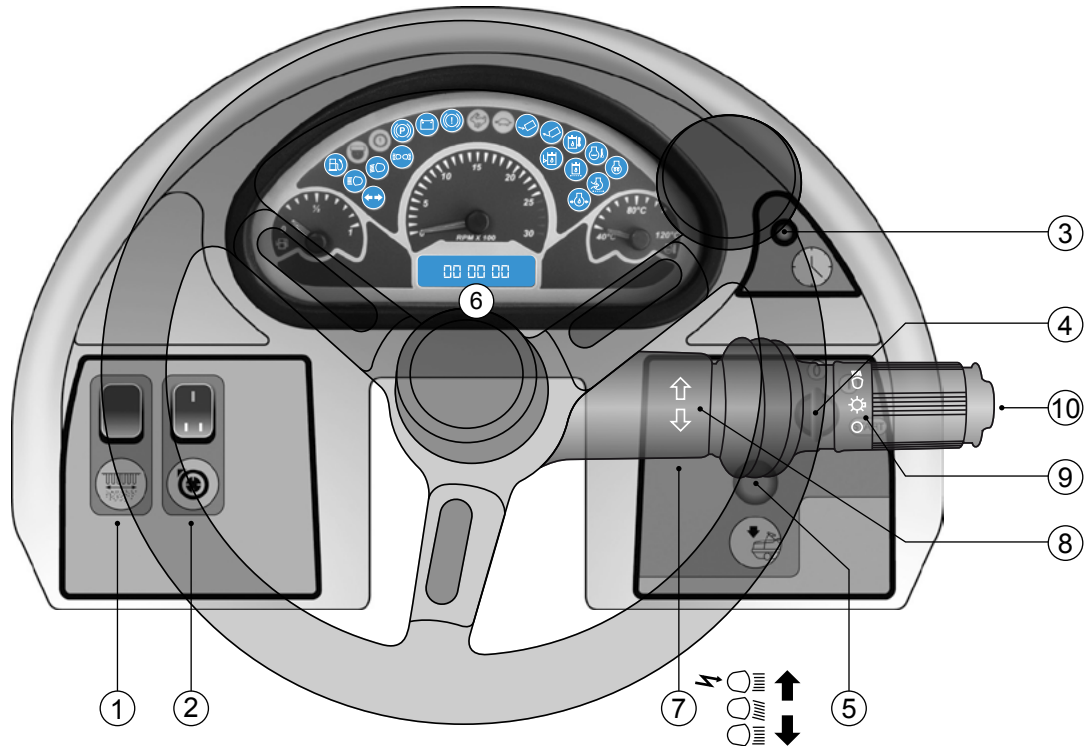

INSTRUMENT PANEL BUTTONS

- | | |
|--|---|
| 1 Filter shaker switch | 6 Hour meter |
| 2 Suction turbine switch (100-120 D-Bifuel only) | 7 Light switch (raise and lower the lever) |
| 3 Partial hours display button | 8 Direction indicators (push the lever forwards/ backwards) |
| 4 Start-up key | 9 Light controller (turn the selector) |
| 5 Safety button for lowering the hopper | 10 Horn |

INSTRUMENT PANEL WARNING LIGHT

- | | |
|--|---|
| Yellow indicator light - fuel reserve
Indicates the light oil reserve | Red indicator light - low hydraulic oil level
Top up the level in the hydraulic circuit |
| Low-beam light green warning light
Lights on | Red indicator light - hydraulic oil temperature
Fault in the hydraulic circuit or radiator |
| Green indicator light - side lights
Optional for the street version | Red indicator light - hydraulic oil filter clogged
Check and clean the filter |
| Red indicator light - handbrake
Parking brake engaged | Red indicator light - excessive motor water temperature
Stop the work operation and check the causes |
| Red indicator light - alternator not recharging the battery
Fault to be checked | Yellow indicator light - glowplugs
Activation of motor heating glowplugs |
| Red indicator light - brake oil level
Insufficient brake oil level | Red indicator light - motor air filter clogged
Disassemble and clean the filter |
| Red indicator light - hopper hatch closed
Indicates the closure of the hopper hatch | Red indicator light - low motor oil pressure alarm
Stop the work operation and check the causes |
| Green indicator light - hopper hatch open
Indicates the opening of the hopper hatch | |



COMMANDS AND SYMBOLS USED ON THE MACHINE

VERSIONS 80-90-110

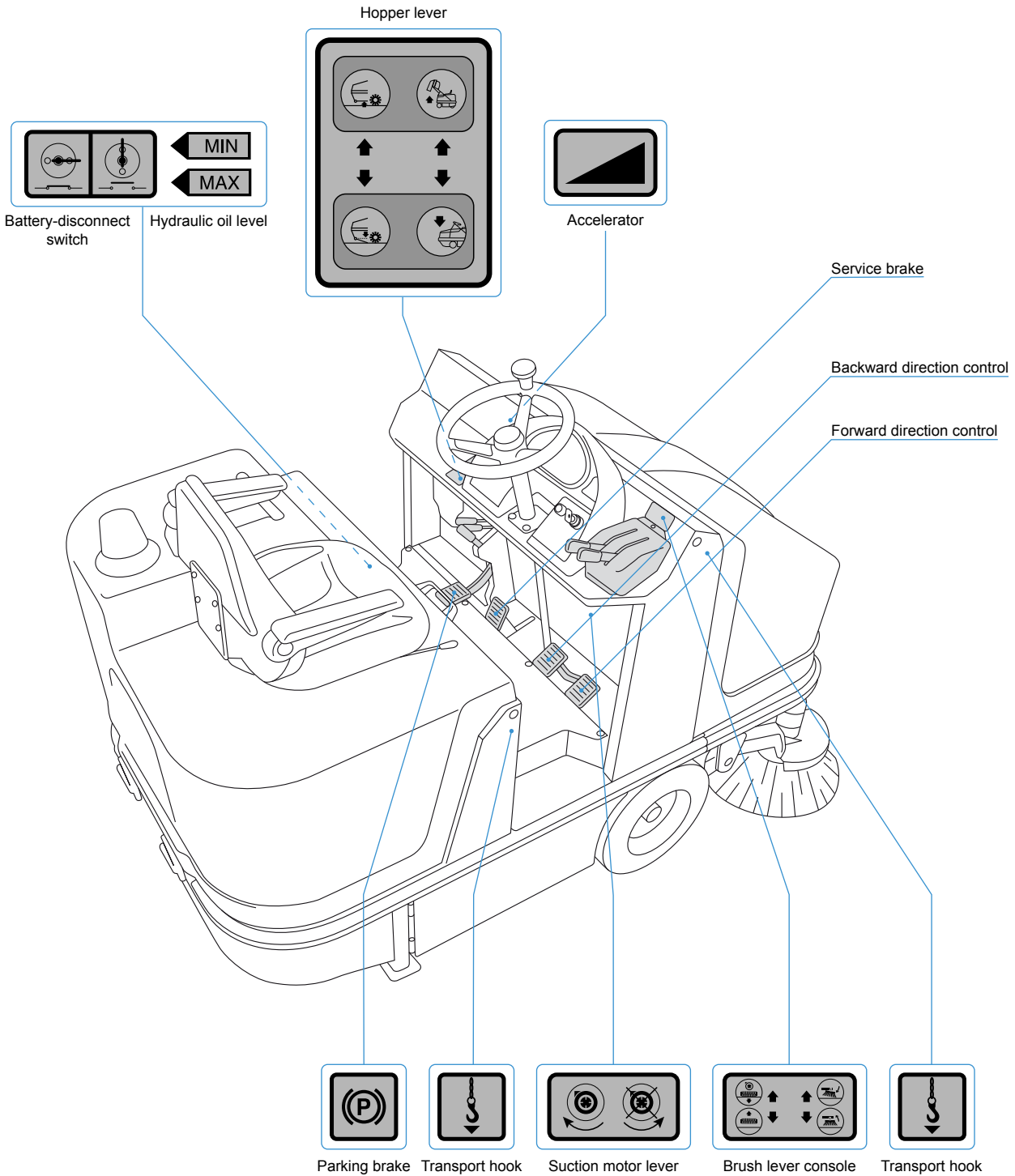



COMMANDS AND SYMBOLS USED ON THE MACHINE

VERSIONS 100-120

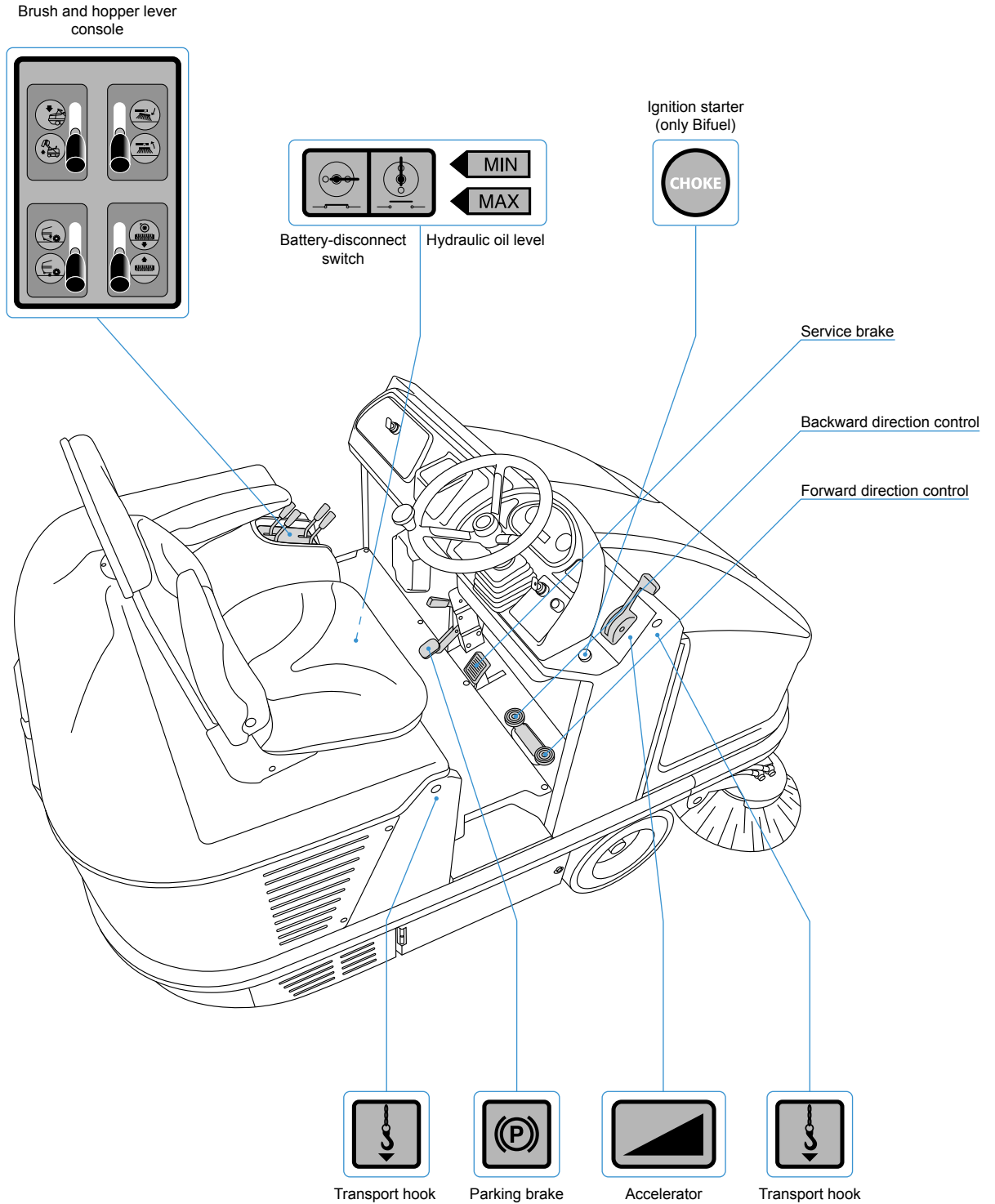



COMMANDS AND SYMBOLS USED ON THE MACHINE

VERSIONS 100-120 ROAD

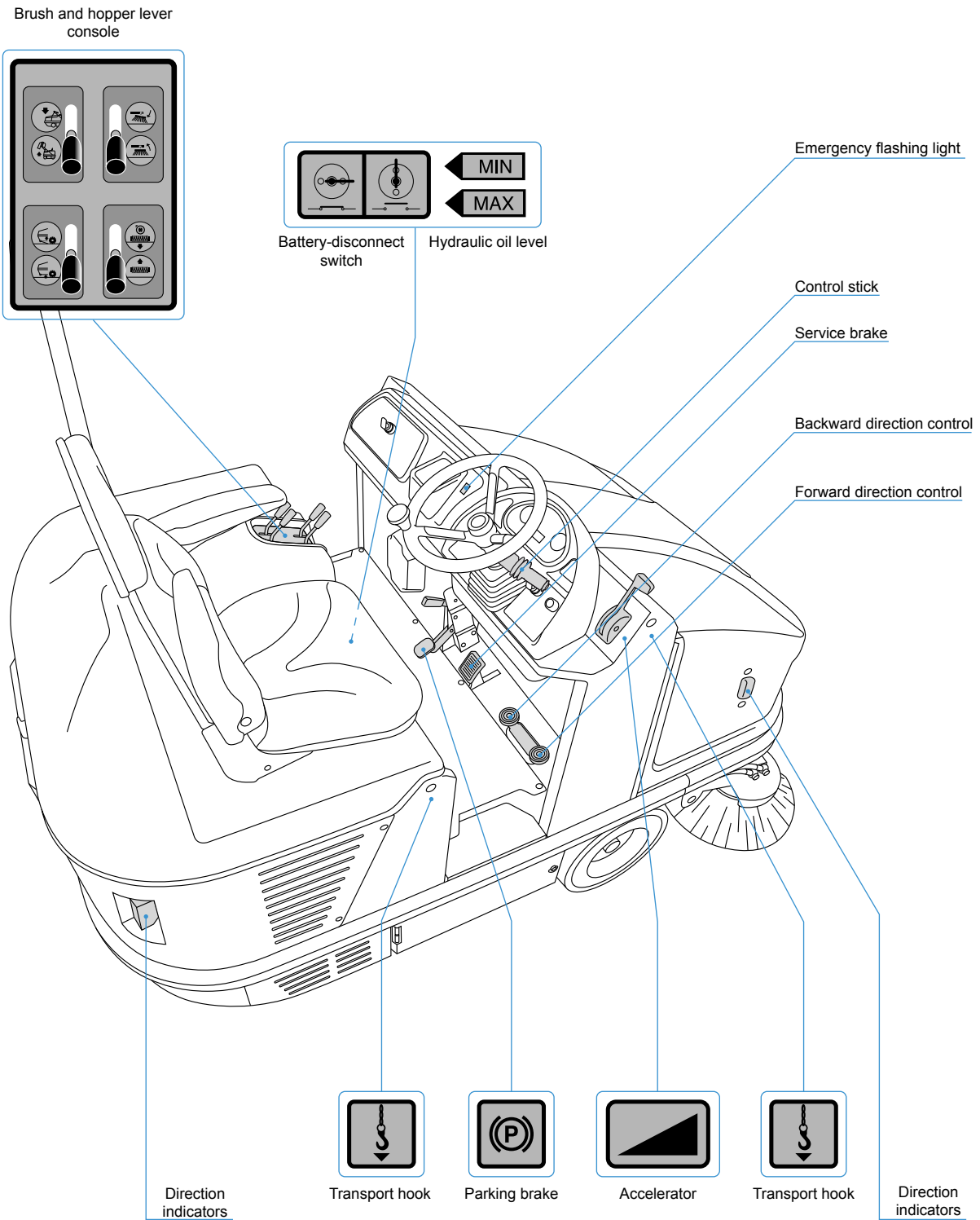



HOW TO UNPACK THE MACHINE

1. HANDLING THE PACKED MACHINE

The machine is delivered packed on a pallet. A forklift or other lifting means (hoist) of a suitable capacity should be used for handling purposes.

If the machine is delivered without any packaging, it should be handled with lifting means of a suitable capacity (hoist, bridge crane), using the special lifting plates supplied with it; fix them to the hooks on the machine itself.

The use of any other lifting system will invalidate the warranty in relation to any damage that may result.

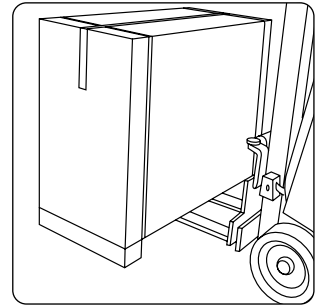

2. HOW TO UNPACK THE MACHINE

To remove the packaging, proceed as follows:

- 1 Remove the supports.
- 2 Remove the metallic points from the packaging base.
- 3 Remove the cardboard.

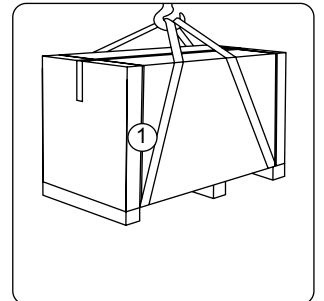

3. GETTING THE MACHINE DOWN FROM THE PALLET

Using a hammer and a lever, remove the wooden wedges (2) that lock the wheels.

Using a pallet, lower the machine.

 **ATTENTION:** read the following section.

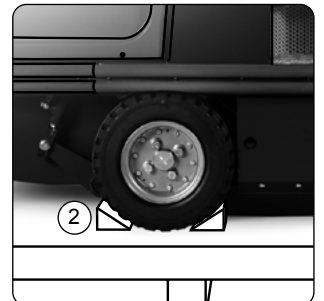

Dimensions of the packaging (in mm) and weight of the packed machine without batteries (1 side brush):

MODEL	DIMENSIONS (mm)	WEIGHT (Kg)
80 B	2330x1640x1790	790
80 D	2330x1640x1790	820
90 B	2330x1640x1790	800
90 D	2330x1640x1790	860
110 B	2330x1640x1790	840
110 D	2330x1640x1790	910
100 B	2330x1640x1790	1030
100 D	2330x1640x1790	1140
120 B	2330x1640x1790	1060
120 D	2330x1640x1790	1170
120 Bifuel	2330x1640x1790	1170

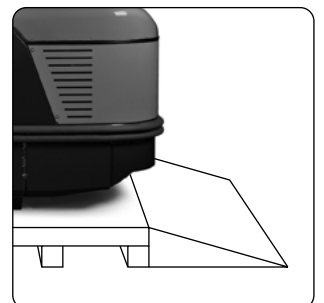



PREPARATION OF MACHINE

1. HANDLING THE MACHINE WITHOUT PACKAGING

To move the machine, without batteries or engine off, proceed as follows, operating on a perfect flat surface.

- 1 Activate the parking brake by pressing the pedal as shown in the figure (A).
- 2 Open the trunk by means of the command (1), rotating it (80-90-110) or pressing it (100-120), then raising it and blocking with the rod.
- 3 Undo the valve (2) installed on the traction pump taking it to the stop position so as to move the machine (100-120). Turn the lever (80-90-110) located between the 2 output pipes by 90°.
- 4 Disengage the parking brake by pushing the lever forwards, as shown in the figure (B).

After moving the machine, restore the former conditions so it can be used.



ATTENTION: the sweeping machines must only be activated by suitably trained and authorised operators, and only after they have ensured that the machine itself is in good working condition.

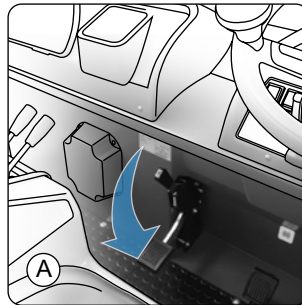

80-90-110-100-120 B-D-Bifuel

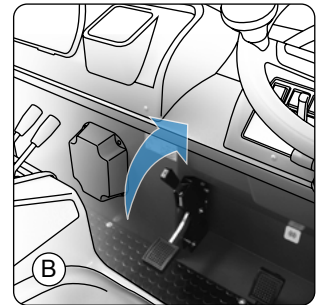

80-90-110-100-120 B-D-Bifuel

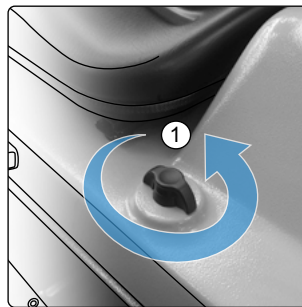

80-90-110 B-D

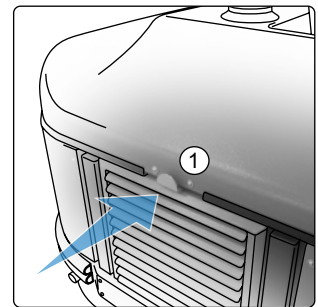

100-120 B-D-Bifuel

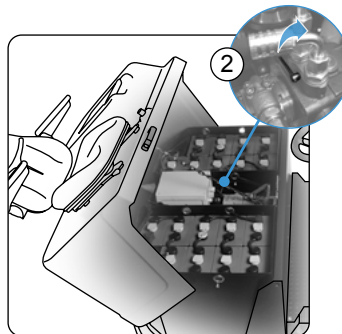

80-90-110 B

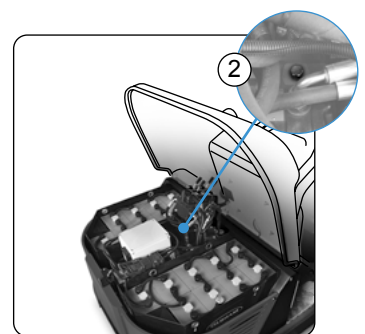

100-120 B

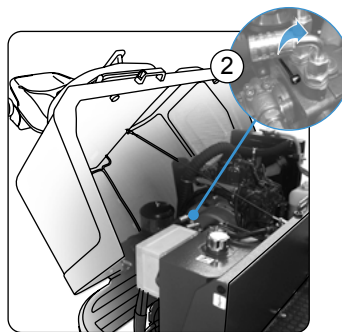

80-90-110 D

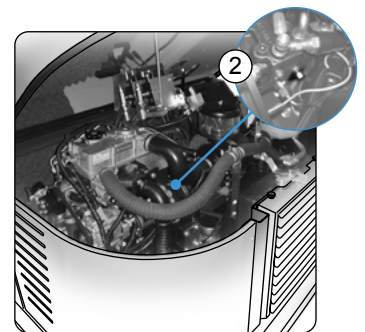

100-120 D-Bifuel



PREPARATION OF MACHINE

2. INSERTING/CONNECTING THE BATTERIES (BATTERY VERSIONS ONLY)

It is recommended to fit 2 battery containers as shown on page 23 in order to have a good autonomy. Before mounting make sure that the batteries are charged.

Assembly instructions:

- 1 Remove the start-up key from the block (1).
- 2 Fully open the rear machine trunk (2).
- 3 Remove the two side panels (3) and the lower battery stop levers (versions 100-120).
- 4 Position the batteries in their compartment (4), respecting the poles. Use only a lifting device suitable for the size and weight to be lifted.
- 5 Connect the jumper cables and the positive and negative pole connections as shown in the figure (A).
- 6 Reposition the side panels (3) (versions 100-120).
- 7 When operation is finished, close the rear trunk (2).



ATTENTION: You are advised to only lift and move the batteries with lifting and transportation means suitable for the specific weight and size.



ATTENTION: users are advised to always wear protective gloves, to avoid the risk of serious injury to hands.



ATTENTION: Indicates the danger of fire

Keep naked flames at a safe distance.



ATTENTION: all the installation operations must be carried out by specialised personnel.

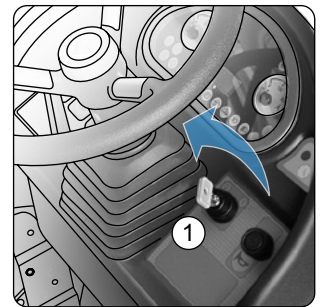

80-90-110-100-120 B

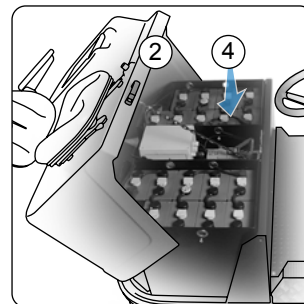

80-90-110 B

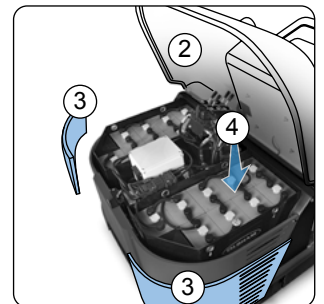

100-120 B

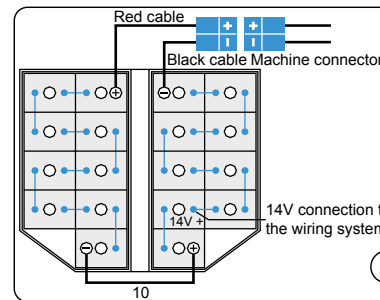

80-90-110-100-120 B

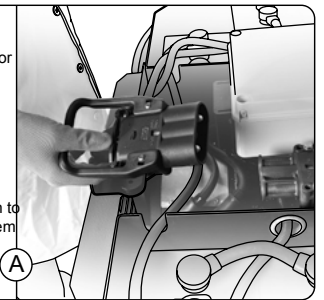

3. CONNECTING THE BATTERY CHARGER

Open the rear trunk (1). Beneath it you will find the female connector (2), to which the male connector (3) (fixed to the battery charger cables) should be connected. The male connector is supplied in a bag and must be connected to the battery charger cables, taking care to respect the polarity. After connecting the machine batteries to the battery charger, recharge them completely.

The battery charger usually provides the necessary charge before automatically switching off.



ATTENTION: never leave the batteries completely discharged, even if the machine is not being used. When recharge is over, check electrolyte level and refill with distilled water if necessary.

ATTENTION: this operation must be carried out by qualified personnel. The incorrect or imperfect connection of the cables to the connector can seriously harm people and damage objects.

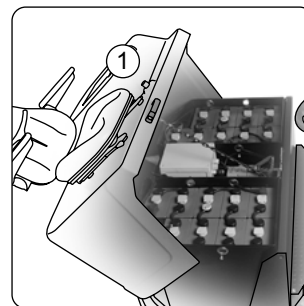

80-90-110 B

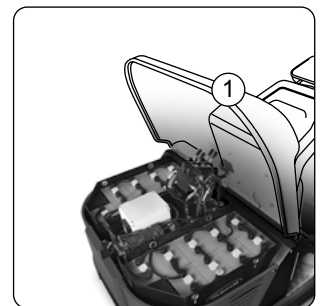

100-120 B

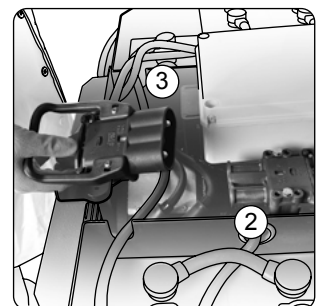

80-90-110-100-120 B



PREPARATION OF MACHINE

ATTENTION: during recharging, keep the seat lifted and locked with the appropriate prop.

Make sure that the battery charger is suitable for the batteries installed as regards their capacity as well as their type (wet or gel batteries and similar).

Never recharge gel batteries with an unsuitable battery charger. Follow the instructions given by the battery/battery charger manufacturer with the utmost attention.

ATTENTION: risk of gas exhalation and corrosive liquids leaks.

ATTENTION: danger of fire: Keep naked flames at a safe distance.

ATTENTION: to avoid permanent damage to the batteries, it is essential to prevent them from running down completely. When the run-down buzzer sounds, all the machine functions must be deactivated apart from the forward movement function (to reach the recharge point).

ATTENTION: any use of controls must be carried out by the operator seating at the driving seat.

4. SIDE BRUSH ADJUSTMENT

To assemble the brush:

- 1 Check the parking brake (1) is engaged.
- 2 Turn the wrench (2) clockwise the start-up the machine (see chapter 8).
- 3 Check the battery charge is sufficient for carrying out the work envisaged (B versions).
- 4 Close the hatch of the debris hopper:
80-90-110: pushing the lever (3) up
100-120: pushing the lever (4) back.
- 5 Raise the debris hopper until it reaches the required height:
80-90-110: pushing the lever (5) up
100-120: pushing the lever (6) back
- 6 Assemble the brush, blocking it with the bolt (7) supplied.
Lower the hopper by means of the hatch closing lever.

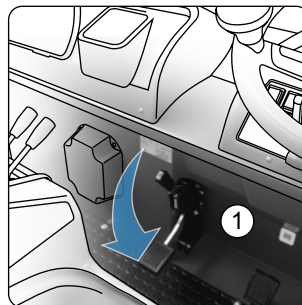

80-90-110-100-120 B-D-Bifuel

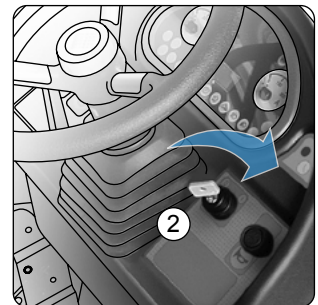

80-90-110-100-120 B-D-Bifuel

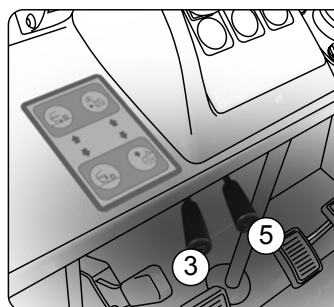

80-90-110 B-D

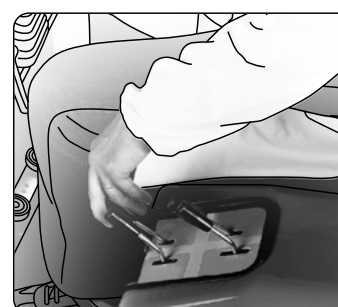
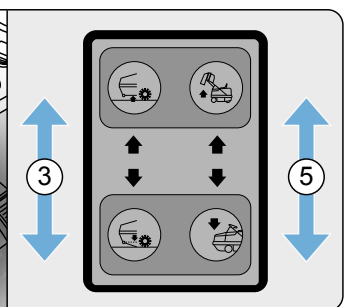

100-120 B-D-Bifuel

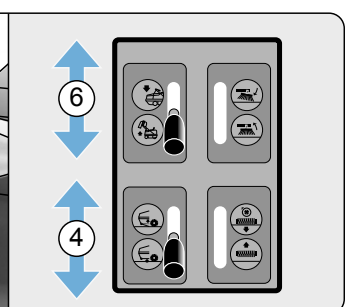



INITIAL START-UP AND USE OF THE MACHINE

For safety reasons, the hopper can only be lowered by pressing the green button (8) on the front instrument panel and simultaneously using the hopper lowering lever (5) 80-90 -110 - (6) 100-120.

After bringing the debris hopper back to its working position, reopen the hatch by pushing the lever (3) 80-90-110 (4) 100-120.

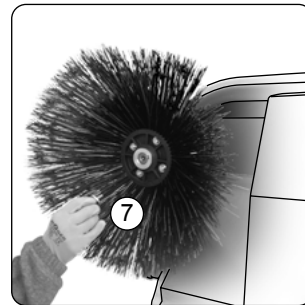

80-90-110-100-120 B-D-Bifuel

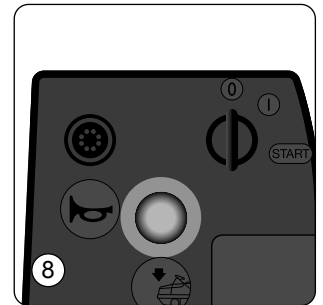

80-90-110-100-120 B-D-Bifuel

1. MACHINE START-UP

Before carrying out any type of work:

- 1 Make sure the parking brake is disengaged by pressing the pedal and pushing the lever (1) forward, then release the pedal.
- 2 Turn the key (2) clockwise to start the machine.

B versions:

- 3 check the battery charge is sufficient for carrying out the work envisaged.

D versions:

- 4 Fill the tank with diesel with low sulphur content, see figure (A)

The maximum capacity is 18 litres, including a 4-litre reserve. Check the level of oil in the hydraulic circuit (via the bulb indicator lights). The difference between the two ends is about 1.5 litres. Check the motor oil level.

Check the position of the battery cut-out: bring it to the working (horizontal) position.

- 5 Check the acceleration lever is in the idle position (5).
- 6 Turn the start-up key, bringing it to the warm-up position (2). Wait about 6 seconds, until the glowplug indicator light switches off.

When the indicator light is OFF, turn the key to the start position.

When the motor switches on, release the key.

After first heating phase, the machine can operate within 1800-2400 rpm for the 100-120 and 2000-2800 rpm for the 80-90-110.

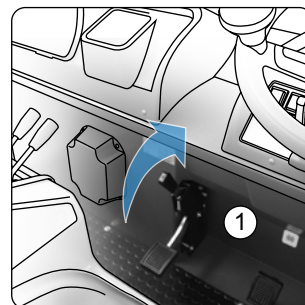

80-90-110-100-120 B-D-Bifuel

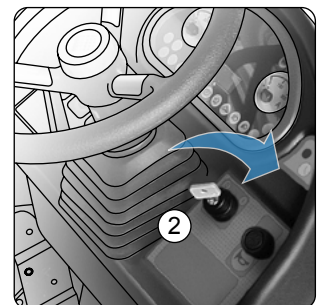

80-90-110-100-120 B-D-Bifuel

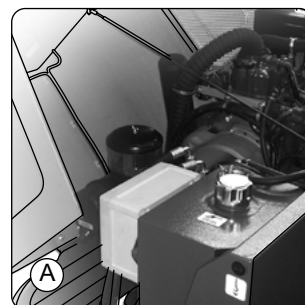

80-90-110 D

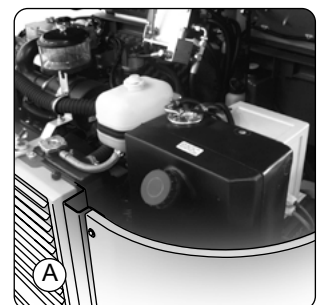

100-120 D

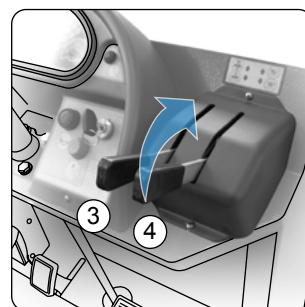

80-90-110 B-D

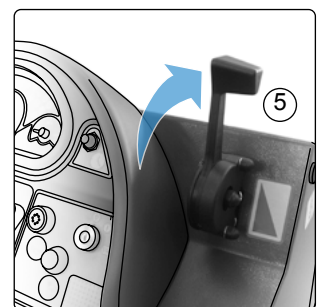

80-90-110-100-120 D-Bifuel



INITIAL START-UP AND USE OF THE MACHINE

Bifuel versions:

- 7 Install the LPG cylinder following the instructions supplied. Refill the tank with unleaded petrol (capacity 10 l)
- 8 To start with cold machine, use the starter and leave it engaged for the necessary time.



ATTENTION: ask qualified personnel to check LPG cylinder installation and its correct operation as well as connections integrity.

ATTENTION: Bifuel version can work with unleaded petrol as well as with LPG.

Select the desired fuel with the selector (see diesel-Bifuel versions tools page)

B-D-Bifuel versions:

- 9 In the working place activate the lever upwards to lower the central brush (3) and the right side brush (4).
If the left side brush is present, activate the specific lever.
- 10 the machine works in normal conditions with the hatch open, as the dirt is collected by the central brush and pushed into the debris hopper.
Check the hopper is lowered. Using the hatch lever to lower it, the green LED lights up on the instrument panel, showing the hopper is open and therefore allowing the dirt to be collected.
- 11 Activate the intake turbine by the specific command (6), do not use the suction system if you are working on wet surfaces.
- 12 press the double pedal to activate the traction and impose a suitable machine speed for the quantity of dust and debris on the floor. To move forwards, press the right side of the pedal (7); to move backwards, press the left side (8).
- 13 If the machine needs to be transferred without functioning, you are advised to raise the brushes.

Respect the warnings indicated in the engine maintenance and use manual for the start-up operations (engine ignition).



ATTENTION: the machine is fitted with a dead man's micro-switch beneath the seat; this prevents the machine from moving if the operator is not correctly seated.

ATTENTION: avoid prolonged use of the filter shaker motor. Shut off the suction function by means of the hatch lever when you are about to clean wet or damp surfaces, to avoid ruining the filter.

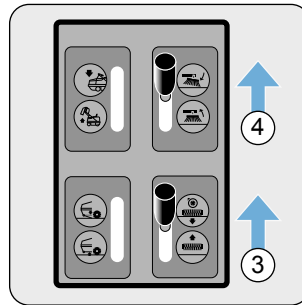

100-120 B-D-Bifuel

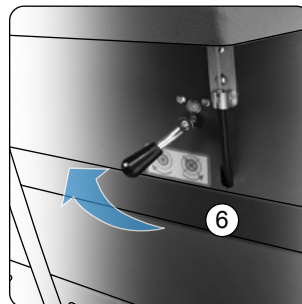
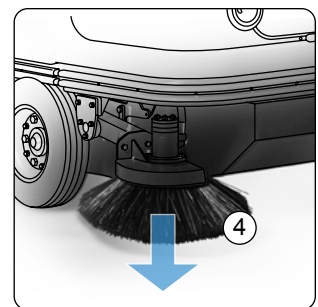
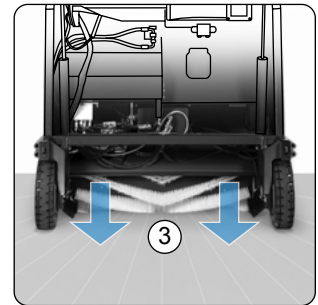

80-90-110 B-D

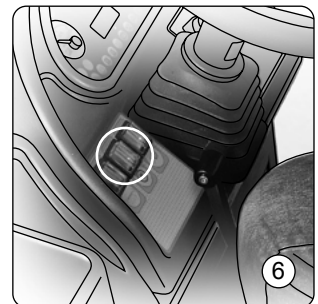

100-120 B-D-Bifuel

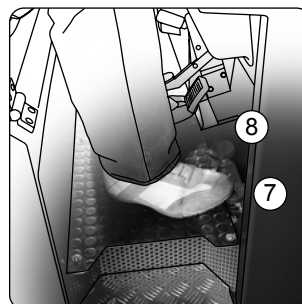

80-90-110-100-120 B-D-Bifuel

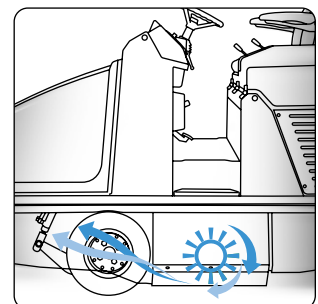



INITIAL START-UP AND USE OF THE MACHINE

2. FILTER SHAKER ACTIVATION AND DEBRIS HOPPER EMPTYING

If the machine has problems to carry out collection, check the debris hopper filling state and, if necessary, empty it.

Before unloading operations, it is advisable to clean the machine filter by means of the filter shaker.

To activate the filter shaker, proceed as follows:

Press the filter shaker switch (1) on the instrument panel to activate the filter shaker motor and free the dirt captured by the filter itself.

Before activating it, always deactivate the intake turbine (2).

To obtain efficient suction, clean the filter roughly every 20-30 minutes, and always before emptying the debris hopper.

Keep in mind that the weight of the waste collected is proportional to the specific weight of the material swept. In the case of heavy material like sand, soil, gravel, etc., you are advised not to fill the hopper more than about 70%, as otherwise it may be difficult to empty it.

Place next to the debris hopper prepared for unloading.

To raise the debris hopper, proceed as follows:

1 Close the hatch:

80-90-110: pushing the lever (3) up.

100-120: pushing the lever (4) back.

2 Raise the debris hopper until it reaches the required height:

80-90-110: pushing the lever (5) up.

100-120: pushing the lever (6) back.

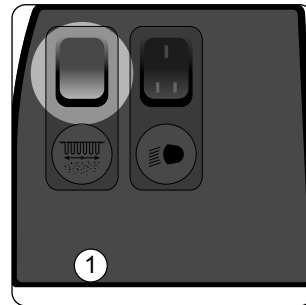

80-90-110 B-D

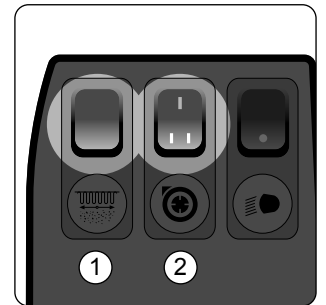

100-120 B-D-Bifuel



80-90-110 B-D

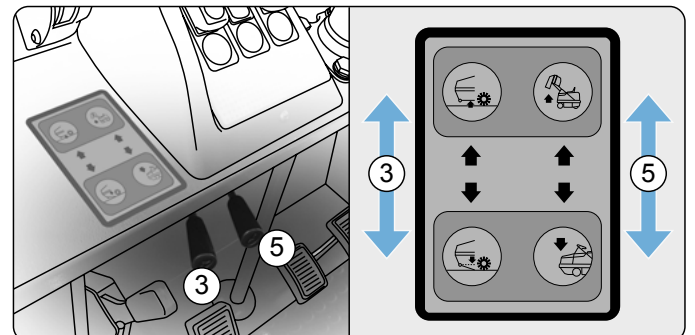

80-90-110 B-D

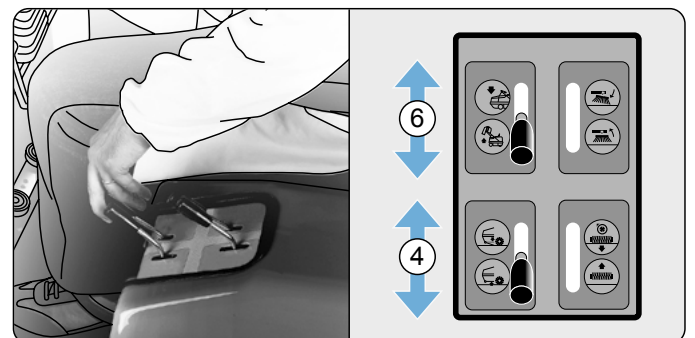

100-120 B-D-Bifuel



INITIAL START-UP AND USE OF THE MACHINE

- 3 Take the debris hopper (7) back and place the unloading mouth as low as possible.
- 4 Slowly open the lid to allow collected debris unloading:
80-90-110: pushing the lever (3) down.
100-120: Pushing the lever (4) forwards.

After emptying, use the hatch lever to close it.

For safety reasons, the hopper can only be lowered by pressing the green button (8) on the front instrument panel with your right hand, and simultaneously using the hopper lowering lever (5) 80-90 -110 - (6) 100-120.

After bringing the debris hopper back to its working position, reopen the hatch by pushing the lever (3) 80-90-110 (4) 100-120.

At this point, you can carry on working.



ATTENTION: before emptying the debris hopper, close the lid by activating the lever and make sure that there are no people in the machine working area.

ATTENTION: with debris hopper up, move the machine very slowly. maximum speed 1km/h. Avoid unloading the debris while the machine is on a slope. Do not activate the filter shaker when the hopper is raised.

After emptying, use the hatch lever to close it.

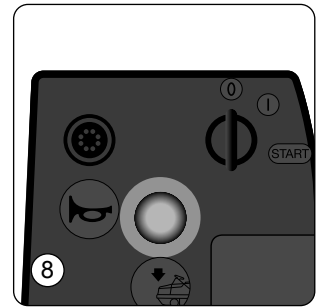

80-90-110-100-120 B-D-Bifuel

3. FRONT VACUUM HOSE KIT

To use the optional front vacuum hose kit, proceed as follows:

- 1 Engage the parking brake.
- 2 Get off the machine, go to the front of the machine and remove the cover plate (1) located at the front of the debris hopper.
- 3 Remove the front vacuum hose from the support.
- 4 Fit the flange in the vacuum hose (2) into the front part of the debris hopper.
- 5 Activate the suction turbine using the appropriate command (3); remember to activate it at maximum power.
- 6 Vacuum the dirt.



ATTENTION: please note that when using the front vacuum hose, it is compulsory to close the door of the debris hopper.

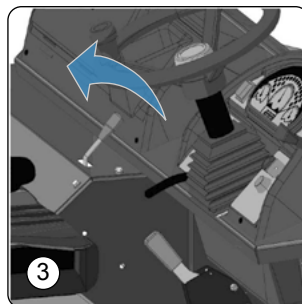
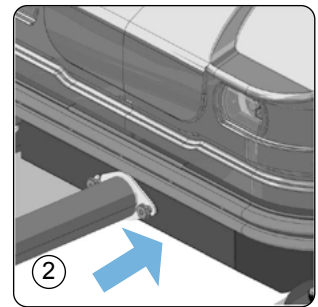
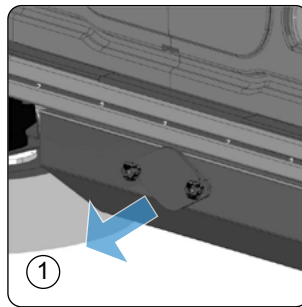



RECOMMENDED MAINTENANCE

WARNINGS

The regular, periodic maintenance of the sweeping machine ensures better performance levels and a longer working life.



ATTENTION: remove the key from the panel when carrying out maintenance operations.

1. FILTER CLEANING

The pocket filter does not require maintenance at all, just use the filter shaker periodically. If a suction drop is detected, clean the filter carefully in the following way:

- 1 Turn off the machine
- 2 Open the front trunk by the closing hook (1) and lock it in open position
- 3 Lift the protection panel to reach the filter, by activating the side hooks
- 4 Remove the filter completely (to be performed by 2 people) after disconnecting the cable connector of the shaker filter engine placed in the lower part of the filter frame
- 5 Carefully clean the filter using a suction vacuum with filter suitable to the type of dust to remove
- 6 Reassemble everything in reverse order. Pay special attention to the seal, replacing it immediately if it is damaged.



ATTENTION: these operations must be carried out with gloves to protect the hands from contact with dangerous elements.

Wear protective goggles and a mask to protect from dust

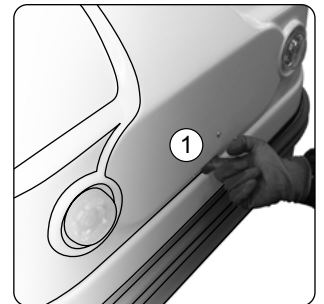

80-90-110-100-120 B-D-Bifuel

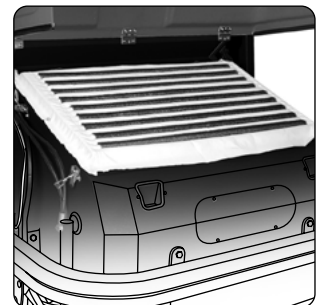

80-90-110-100-120 B-D-Bifuel

2. ADJUSTING SIDE BRUSH

Brush pressure can be adjusted via the screw behind the arm of the side brush:

- 1 Lower the brush.
- 2 Loosen the lock nut (1).
- 3 Turn the set screw clockwise or anticlockwise to reduce or increase ground pressure.

Side brush inclination can be adjusted by loosening the bolts (2) and place it along the slot and locking it in the desired position.



ATTENTION: these operations must be carried out using gloves to protect the hands.

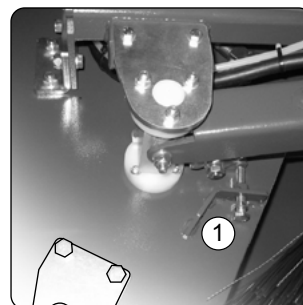

80-90-110-100-120 B-D-Bifuel





RECOMMENDED MAINTENANCE

3. CENTRAL BRUSH PRESSURE ADJUSTMENT

Central brush adjustment allows varying ground position fitting it to cleaning demands and restoring correct pressure that varies with wear.

- 1 Open the left side lid by pressing and turning the closing pin (1) anticlockwise.
- 2 Operate on the handle (2) turning it anticlockwise to increase position or clockwise to decrease it.
- 3 Close the lid by pressing and turning the pin.

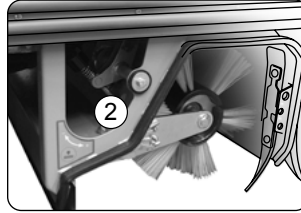
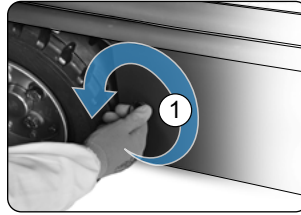

80-90-110 B-D

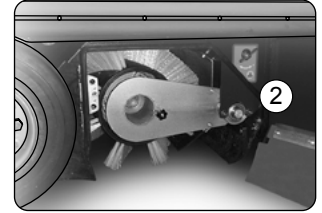

100-120 B-D-Bifuel



ATTENTION: these operations must be carried out using gloves to protect the hands.

4. CENTRAL BRUSH REPLACEMENT

- 1 Turn off the brush engine by activating the lifting lever of the brushes (see chapter 8).
- 2 Turn off the machine with key in position 0 and engage the parking brake
- 3 Open the left side lid by pressing and turning the closing pin (see chapter 12)
- 4 Unscrew the knob (1) for versions 100-120, open the lever (2) for versions 80-90 -110 and remove the brush support (3)
- 5 Remove the used brush and insert a new one paying attention to inserting it in the right place.

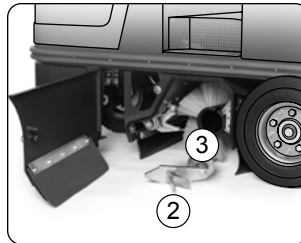

80-90-110 B-D

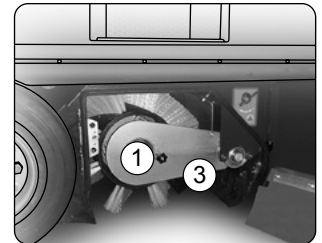

100-120 B-D-Bifuel



ATTENTION: the brushes have bristles placed on top, therefore, fit them in the correct direction.

ATTENTION: these operations must be carried out using gloves to protect the hands.

5. LID FLAP RUBBER REPLACEMENT

- 1 Undo the 4 fixing bolts (1) and slide the rubber pressing strip (2).
- 2 Remove the worn flexible rubber (3) and replace it with a new one so as to discharge on the floor.
The external rubber more rigid is placed at 15-20 mm from the floor
- 3 Refit the strip and the fixing screws.

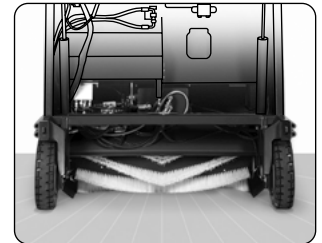

ATTENTION: these operations must be carried out using gloves to protect the hands.

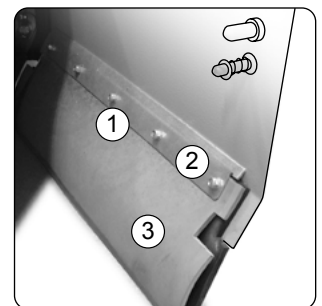

80-90-110-100-120 B-D-Bifuel

6. REAR FLAP RUBBER REPLACEMENT

- 1 Undo the two bolts (1-2).
- 2 Slide completely the rubber from the supporting base.
- 3 Refit the rubber with the support using the slots to adjust and fix it with bolts (1-2) The rubber distance from the floor must be from 1 to 3 mm.

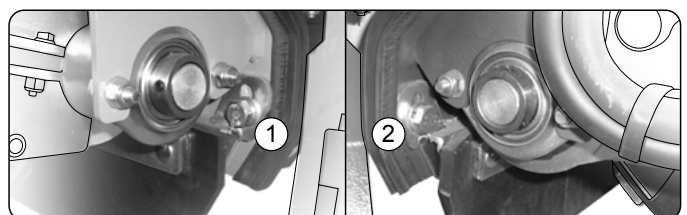

100-120 B-D-Bifuel



RECOMMENDED MAINTENANCE

7. HYDRAULIC TRANSMISSION MAINTENANCE

The hydraulic oil level must be checked with cold machine and with debris hopper lowered.

Refill the hydraulic transmission tank, placed under the rear trunk, with hydraulic oil ARNICA 46 or similar, when the level goes under the minimum visible from the lower transparent plug present on the wall under the operator seat.



ATTENTION: if the red warning light of the instrument panel turns on, immediately stop the machine.

ATTENTION: protect yourself with DPI suitable for hydraulic oil.

ATTENTION: for all other maintenance operations, you are advised to contact our technical assistance centre (organised in collaboration with our dealers), as these interventions require specific technical skills and the use of the right equipment.

ATTENTION: oil must be replaced every 1000 hours, regardless of its level.

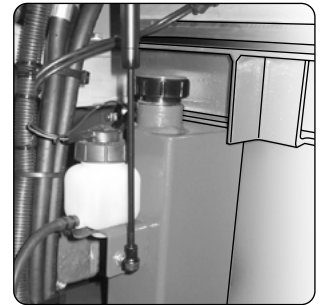

80-90-110-100-120 B-D-Bifuel

8. HYDRAULIC OIL FILTER REPLACEMENT

Change the hydraulic oil filter every 300 hours or when the instrument panel warning light is on, proceed as follows:

- 1 Stop the machine, engage the parking brake (1) and turn the key (2) to position 0.
- 2 Wrap the oil tank plug with insulation tape, in order to close the vent.
- 3 Open the lid in the right side of the machine by pressing and turning the closing pin (see section 13) and place a tank under the filter to collect small leaks.
- 4 Unscrew the filter (3) and replace it.
- 5 Close the lid by pressing and turning the pin



ATTENTION: dispose of the filters and used oil in the correct manner

ATTENTION: protect yourself with DPI suitable for hydraulic oil

ATTENTION: for all other maintenance operations, you are advised to contact our technical assistance centre (organised in collaboration with our dealers), as these interventions require specific technical skills and the use of the right equipment.

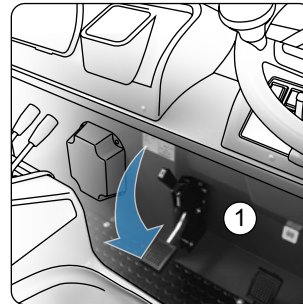

80-90-110-100-120 B-D-Bifuel

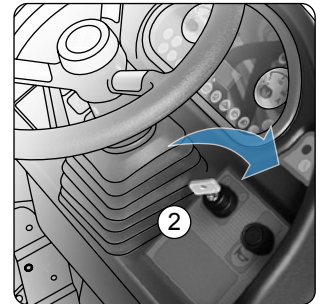

80-90-110-100-120 B-D-Bifuel

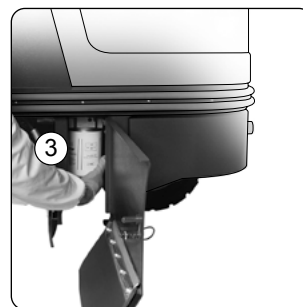

80-90-110 B-D

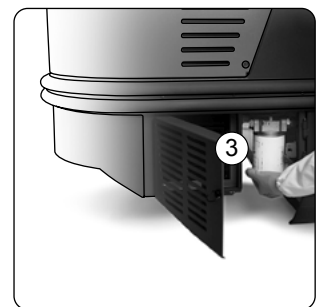

100-120 B-D-Bifuel



RECOMMENDED MAINTENANCE

9. ENGINE OIL LEVEL CHECK (D-BIFUEL)

Engine oil level check must be carried out every time the machine is used.

- 1 Stop the machine on a flat surface, engage the parking brake.
- 2 Place the key in position 0 and remove it.
- 3 Open the engine trunk and hold it with supporting struts.
- 4 Check oil level with the rod (1) and restore the level.
- 5 If it is lower than the MIN level, consult the engine manual.

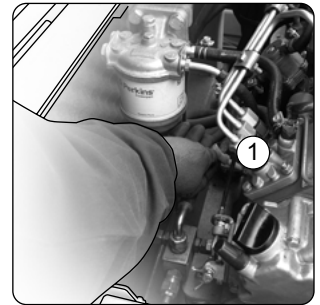

100-120 B-D-Bifuel



ATTENTION: these operations must be carried out using gloves to protect the hands

ATTENTION: do not touch the hot parts of the engine

10. ENGINE AIR FILTER CLEANING

The engine is protected by three filter for intake air:

- Cyclone pre-filter to separate the heavier parts
- Primary cartridge for general dust
- Safety cartridge for subtle particles

Daily check the filter, remove dirt and debris, if necessary.

Primary cartridge can be cleaned, if necessary, four or six times before replacing it, replace it at least once a year.

Safety cartridge does not have to be cleaned, but should be replaced every two or three cleanings of the primary filter.

For further information, refer to the manual supplied with the engine.

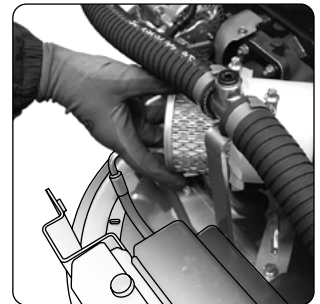

100-120 B-D-Bifuel



ATTENTION: these operations must be carried out using gloves to protect the hands.

ATTENTION: do not touch the hot parts of the engine.



ATTENTION: empty the debris hopper before any intervention.

ATTENTION: carry out interventions by keeping the debris hopper raised, use the safety supports (1) supplied with the machine.

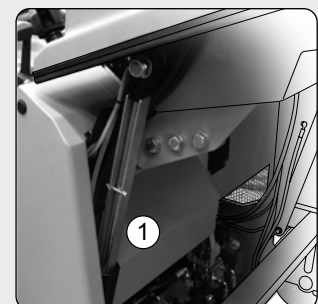



CHOOSING AND USING THE BRUSHES

1. POLYPROPYLENE BRUSH (PPL)

It is used on every type of floors and has good resistance to wear. PPL is non-hygroscopic and therefore retains its characteristics even when working in wet conditions.

2. BRISTLE THICKNESS

The thicker bristles are more rigid and should therefore be used on surfaces with solid or heavy dirt (e.g. gravel, drinks cans, etc.).

Softer bristles are recommended for surfaces with light dirt or dust.

Remember that when the bristles are worn, and therefore too short, they become rigid and cannot pick up the dirt efficiently. Central brush has bristles of 1.1mm and of 0.7mm to comply with both characteristics.

CENTRAL BRUSH TABLE

MACHINE	CODE	TYPE OF BRISTLES	DIMENSIONS
80	429189	PPL 1,1+0,7	800x320
	429200	PPL 0,7	800x320
	429021	PPL 1,4	800x320
90	429202	PPL 1,1+0,7	900x320
	429203	PPL 0,7	900x320
	429204	PPL 1,4	900x320
110	431115	PPL 1,1+0,7	1100x320
	431117	PPL 0,7	1100x320
	431116	PPL 1,4	1100x320
100	424902	PPL 1,1	1000x320
	424904	PPL 0,7	1000x320
	424906	PPL 1,4	1000x320
120	424903	PPL 1,1	1200x320
	424905	PPL 0,7	1200x320
	424907	PPL 1,4	1200x320

SIDE BRUSH TABLE

MACHINE	CODE	TYPE OF BRISTLES	DIMENSIONS
80 - 90 - 100	429205	PPL 1,1 ACC. 0,7	Ø450
	429206	PPL 1,0	Ø450
100 - 120	411695	PPL 1,1 ACC. 0,7	Ø500
	424909	PPL 1,5	Ø500

Replace the central brush when the bristle height is 15-20 mm.

BATTERY CONTAINER DIMENSION

BATTERY CONTAINER DIMENSIONS (mm)								
Machine	A	B	C	D	E	F	Height	Capacity Ah/C5
80 B	595	295	515	80	80	215	450	320
90 B	620	420	500	120	210	210	450	480
110 B	620	420	500	120	210	210	450	480
100 B	800	420	640	160	210	210	460	640
120 B	800	420	640	160	210	210	460	640

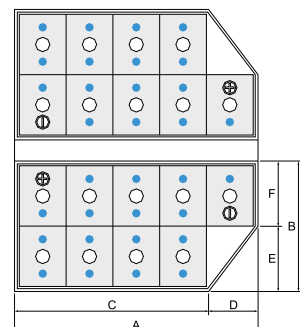



RECOMMENDED PERIODIC MAINTENANCE OPERATIONS

Version	Procedure	Upon delivery	Daily maintenance	After the first 50 hours	Every 50 hours	Every 150 hours	Every 300 hours	Every 500 hours	Every 1000 hours	Every 2000 hours	Every 3000 hours
B-D-BF	Hydraulic oil level check	C	C								
B-D-BF	Parking brake check		C								
B-D-BF	Brush cleaning		C								
B-D-BF	Central brush replacement										
B-D-BF	Side brush replacement										
B-D-BF	External cleaning of hydraulic oil radiator				C		S (3)				
B-D-BF	Brush adjustment check						S	S	S	S	
B-D-BF	Filter shaker functioning check		C		C						
B-D-BF	Flap condition check				C						
B-D-BF	Flap replacement							S (4)	S (4)		
B-D-BF	Seal condition check (oil leaks)						S	S	S		
B-D-BF	Bearing greasing						S	S	S		
B-D-BF	Hydraulic oil replacement							S (1)	S (1)		
B-D-BF	Hydraulic oil filter replacement						S	S	S		
D-BF	Check for leaks in cooling circuit	C	C								
D-BF	Engine coolant check	C	C								
D-BF	Engine oil replacement			S				S	S		
D-BF	Engine oil replacement			S				S	S		
D-BF	Engine air filter cleaning				C						
D-BF	Engine air filter cleaning										
D-BF	Alternator belt check			C	C						
D-BF	Battery liquid level check			C			C	C	C		
D-BF	External cleaning of motor radiator				C						
D-BF	Fuel filter replacement							S	S		
D-BF	Motor alternator belt replacement										
D-BF	Tightening of screws and fuel fittings						S	S	S		
D-BF	Motor valve play check										
D-BF	Motor vent replacement									S	
D-BF	Injector yield check										S

KEY

B: Battery - D: Diesel - BF: Bifuel

- (1) The first time after 500 hours, then every 1000 hours.
- (2) Every 250 hours if the ground is smooth; every 150 hours if it is rough.
- (3) Every 175 hours if the ground is smooth; every 100 hours if it is rough.
- (4) Every 500 hours if the ground is smooth; every 300 hours if it is rough.
- (5) B versions: for battery maintenance, respect the manufacturer's indications.
- (6) Operations to be carried out by the user (C) or the Technical Assistance Service (S)



REPAIR OF POSSIBLE FAILURES

Problem	Possible causes	Solution
The machine does not move	Disconnected battery	Connect the battery
	Machine without fuel	Refill it
	Circuit protection fuses	Restore the fuses
	Parking brake engaged	Disengage it
	Hydraulic unlocking screw in incorrect position	Turn it correctly
The central brush does not turn	Central brush lever raised	Lower the central brush with the lever
	Debris around the brush transmission	Remove the debris
	Debris hopper not completely lowered	Lower the debris hopper completely
The central brush does not clean	Worn central brush	Replace the brush
	Full debris hopper	Empty the debris hopper
	The brush does not turn	Call the authorised technical assistance centre
	The brush does not have enough pressure	Adjust the pressure by operating on the appropriate handle (see chapter 12)
Excessive or altered noise of the central brush	Dirt around the brush	Remove the dirt
The machine lifts dust during operation	Intake system off	Turn on the intake system with the switch
	Clogged dust filter	Clean the dust filter
	Full debris container	Empty the debris container
	Damaged or incorrectly adjusted flap	Check integrity and correct adjustment of the flap (*)
	Incorrect central brush ground height	Adjust the ground height of the brush
The side brush does not work	Side brush lever raised	Lower the side brush with the lever
	Debris around the brush transmission	Remove the debris
	Debris hopper not completely lowered	Lower the debris hopper completely
The unloading lid of the debris container does not close	Quick unloading lid locked by debris	Remove the debris and the dirt from the compartment edge
The filter shaker engine does not work	The filter shaker engine connector is not correctly connected	Restore connections
	Circuit protection fuse	Restore the fuse



TECHNICAL DATA

TECHNICAL DESCRIPTION	U/M	FS80 B	FS80 D	FS90 B	FS90 D	FS110 B	FS110 D
Working width with central brush	mm	800	800	900	900	1100	1100
Working width with one/two side brushes	mm	1120/1440	1120/1440	1220/1540	1220/1540	1420/1740	1420/1740
Working capacity with 1 side brush	m ² /h	9520	10080	10370	10980	12070	12780
Max gradient at full load	%	10	15	10	15	10	15
Central brush dimension (øxL)	mm	320x800	320x800	320x900	320x900	320x1100	320x1100
Theoretical/useful debris hopper volume	ON	370/190	370/190	400/220	400/220	485/270	485/270
Dumping height	mm	1400	1400	1400	1400	1400	1400
Flow rate intake	m ³ /h	160	160	160	160	160	160
Filtering surface	m ²	7	7	8	8	8	8
Forward speed type	-	Aut. hydraulic	Aut. hydraulic	Aut. hydraulic	Aut. hydraulic	Aut. hydraulic	Aut. hydraulic
Forward speed	km/h	0÷8.5	0÷9	0÷8.5	0÷9	0 ÷ 8.5	0 ÷ 9
Machine length	mm	2020	2020	2020	2020	2020	2020
Machine height	mm	1430	1430	1430	1430	1430	1430
Machine height with protection roof	mm	2110	2110	2110	2110	2110	2110
Machine width	mm	1130	1130	1230	1230	1430	1430
Fuel tank capacity	l	-	18	-	18	-	18
Battery voltage and capacity	V/Ah	36/320	-	36/480	-	36/480	-
Electric motor voltage and power	V/W	36/5000	-	36/5000	-	36/500	-
PERKINS diesel engine	HP/Kw	-	14/8.2	-	20/12,2	-	20/12,2
Filter shaker motor	V/W	12/110	12/110	12/110	12/110	12/110	12/110
Battery weight (max)	Kg.	370	-	555	-	555	-
Machine weight when empty	Kg.	700	730	710	770	750	820
TECHNICAL DESCRIPTION	U/M	FS100 B	FS100 D	FS120 B	FS120 D	FS120 Bifuel	
Working width with central brush	mm	1000	1000	1200	1200	1200	
Working width with one/two side brushes	mm	1350/1700	1350/1700	1550/1850	1550/1850	1550/1850	
Working capacity with 1 side brush	m ² /h	9450	11475	10850	13175	13175	
Max gradient at full load	%	10	15	10	15	15	
Central brush dimension (øxL)	mm	380x1000	380x1000	380x1200	380x1200	380x1200	
Theoretical/useful debris hopper volume	ON	570/400	570/400	600/420	600/420	600/420	
Dumping height	mm	1500	1500	1500	1500	1500	
Flow rate intake	m ³ /h	250	250	250	250	250	
Filtering surface	m ²	10	10	11	11	11	
Forward speed type	-	Aut. hydraulic	Aut. hydraulic	Aut. hydraulic	Aut. hydraulic	Aut. hydraulic	
Forward speed	km/h	0÷7	0÷8.5	0÷7	0÷8.5	0÷8.5	
Machine length	mm	2330	2330	2330	2330	2330	
Machine height	mm	1720	1720	1720	1720	1720	
Machine height with protection roof	mm	2171	2171	2171	2171	2171	
Machine height with cabin	mm	2200	2200	2200	2200	2200	
Machine width	mm	1380	1380	1510	1510	1510	
Fuel tank capacity	l	-	18	-	18	10	
Battery voltage and capacity	V/Ah	36/640	-	36/640	-	-	
Electric motor voltage and power	V/W	36/6000	-	36/6000	-	-	
PERKINS 403D-11 Diesel engine	HP/Kw	-	28/17,3	-	28/17,3	-	
KUBOTA DF 972 fuel/LPG engine	HP/Kw	-	-	-	-	28/17,5	
Filter shaker motor	V/W	12/110	12/110	12/110	12/110	12/110	
Battery weight (max)	Kg.	720	-	720	-	-	
Machine weight when empty	Kg.	960	1070	990	1100	1100	

ACCESSORIES

Besides standard supply, the machine can be fitted with the following accessories, according to the use demands.

- LH second side brush

- Safety belts

- Protection roof

- Cabin

- Road approval kit



EC DECLARATION OF CONFORMITY

The undersigned company:

Fimap S.p.A.

Via Invalidi del Lavoro, 1

37059 Santa Maria di Zevio (VR)

declares under its sole responsibility that the

SWEEPING MACHINE mod. 80 B - 80 D - 90 B - 90 D - 110 B - 110 D - 100 B - 100 D - 120 B - 120 D - 120 Bifuel

comply with the provisions of Directives:

2006/42/EC: Machinery Directive.

2014/30/EU: Electromagnetic compatibility directive.

2000/14/EC: Directive by the European Parliament and Council date 8th May, 2000. Noise emission by machines and equipment for outdoor use.

Model	LpA [dB(A)]	LwA, guaranteed [dB(A)]
80 B - 90 B 110 B - 100 B 120 B	71	93
80 D - 90 D 110 D - 100 D 120 D	84	102
120 Bifuel	84	102

Falling into the category of road sweeper as defined in Annex 46 of Directive 2000/14/EC of the European Parliament and the Council, is subject to noise marking only.

The conformity evaluation was carried out in accordance with enclosure III.B.46 of the said directive.

They also comply with the following standards:

EN 60335-1:2012/A11:2014

EN 60335-2-72:2012

EN 12100:2010

EN 61000-6-2:2005/AC:2005

EN 61000-6-3:2007/A1:2011/AC:2012

EN 62233:2008/AC:2008

The person authorized to compile the technical file:

Mr. Giancarlo Ruffo

Via Invalidi del Lavoro, 1

37050 Santa Maria di Zevio (VR) - ITALY

Santa Maria di Zevio 11/11/2020

Fimap S.p.A.

Legal representative

Giancarlo Ruffo

Agent: FIMAP S.p.A.

Via Invalidi del Lavoro, 1

37059 - S. Maria di Zevio (VR) - Verona - Italy

Tel. 0039 045 6060491

Fax. 0039 045 6060440

E-mail: service@fimap.com

Web: www.fimap.com

Manufacturer: COMAC S.p.A.

Via Maestri del Lavoro, 13

37059 - S. Maria di Zevio (VR) - Verona - Italy

Tel. 0039 045 8774222

Fax. 0039 045 8750303

E-mail: com@comac.it

Web: www.comac.it



Fimap spa

Via Invalidi del Lavoro, 1 – 37059 Santa Maria di Zevio – Verona – ITALY

Tel. +39 045 6060411 – Fax +39 045 6060417 – E-mail: fimap@fimap.com - www.fimap.com